

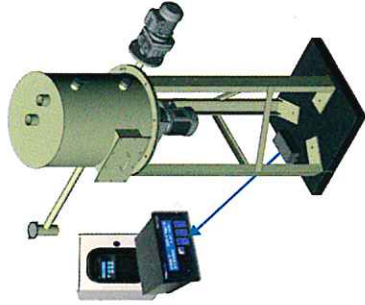

FLUE GAS
Fumées

LOSS-IN-WEIGHT HOPPER

- ▶ Accurate loss-in-weight feeding
- ▶ PLC with many customizable options
- ▶ Remote control available



HYDRO EJECTOR SKID

- ▶ Product transfer over long distances
- ▶ Can be fabricated with pre-wired skid instrumentation
- ▶ No dust emission

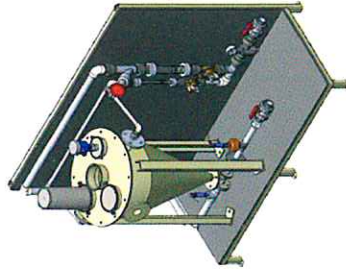

COMPLETE INSTALLATIONS FOR:

- ▶ Soda Ash, Activated Carbon
- ▶ Hydrated lime & quick lime
- ▶ Polymer
- ▶ Sodium Carbonate
- ▶ Microsand
- ▶ Other

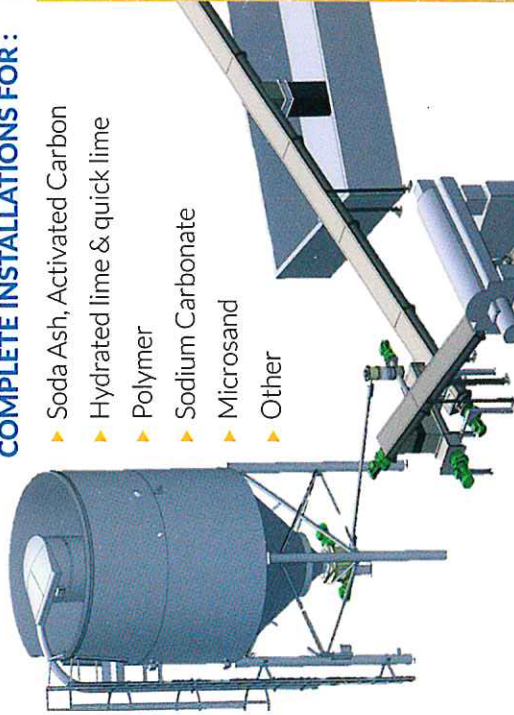

**WITH OVER 9 000
INSTALLATIONS WORLDWIDE**

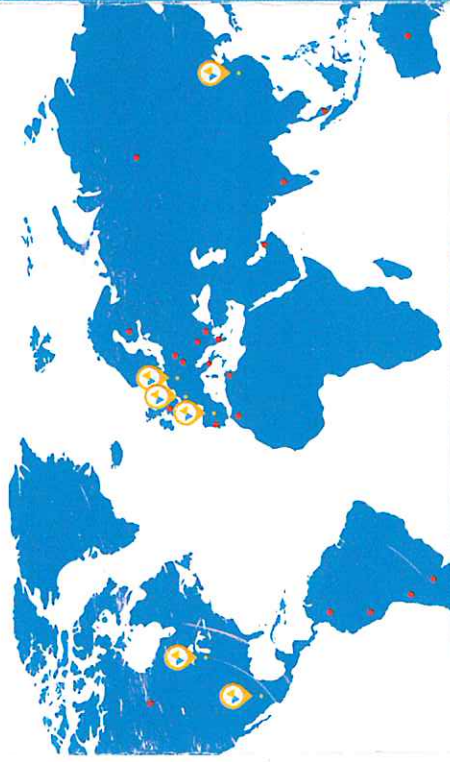

Sodimate S.A.
12 rue Georges Méliès
95240 Corneilles-en-Parisis
France
Tél.: +33 1 30 10 61 70
Email: info@sodimate.com
www.sodimate.com



WASTE WATER
Eau usée



DRINKING WATER
Eau potable



FLUE GAS
Fumées

**STORAGE, DISCHARGE, METERING
AND HANDLING SYSTEMS
FOR BULK POWDERS**





FLUE GAS

Fumées



DRINKING WATER

Eau potable



WASTE WATER

Eau usée

BIN ACTIVATOR ZDM 400 / DDM

- ▶ Constant flow and accurate volumetric feed
- ▶ Can include multiple, independent screw feeders
- ▶ Easy installation

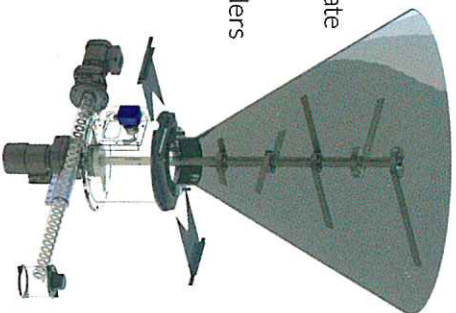

BIG-BAG DISCHARGER

- ▶ Compact units for super sacks/big bags / bulk bags
- ▶ Direct bottom unloading
- ▶ Easy-to-handle
- ▶ Self-loading version available with integrated hoist
- ▶ Supports Big-Bags up to 2 tons

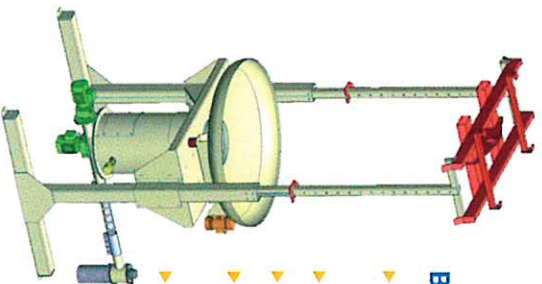

HOPPER WITH UNLOADER ZFP 500 / DDM

- ▶ Sack-tip and buffer hoppers available
- ▶ Mechanical unloading without compaction of product
- ▶ Low power consumption
- ▶ Easy installation

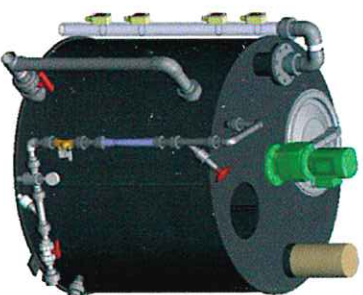
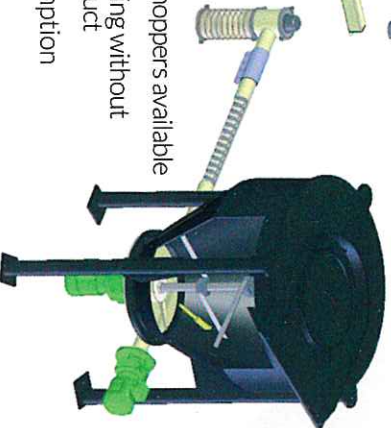

SLURRY TANK

- ▶ Volumes range from 0.5 to 20 m³
- ▶ Fully customizable
- ▶ No dust emission
- ▶ Ideal for use with hydrated lime slurry

PNEUMATIC TRANSFER

- ▶ Wide selection of hoses for any applications
- ▶ Operate with low pressure
- ▶ Low maintenance
- ▶ Possible transport over long distances
- ▶ Low investment
- ▶ Easy installation and start-up

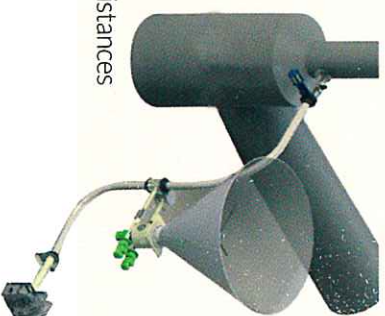

PUMP SKID

- ▶ For use with hydrated lime and activated carbon slurry
- ▶ Pre-mounted skid with flush cycle
- ▶ Fully customizable depending on client's needs



POLYMATE

- ▶ Range of powder and emulsion polymer preparation tank
- ▶ Volume from 0.5 to 5 m³
- ▶ Optimum mixing whatever the type of polymer used

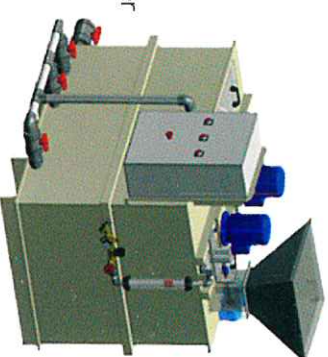

CS SLUDGE CONVEYOR

- ▶ Custom-made and supplied pre-assembled
- ▶ Can be integrated into a complete Sodimate handling system
- ▶ Stainless steel trough and high-resistance auger



MBV SLUDGE MIXER

- ▶ Homogenous and through mixing of lime and sludge
- ▶ Adjustable mixing speed
- ▶ Abrasion-resistant mixing paddles

