



BLAGDON

B50 & X50

AIR OPERATED DOUBLE DIAPHRAGM PUMP

2" Non-Metallic Series

B50

DIMENSIONS

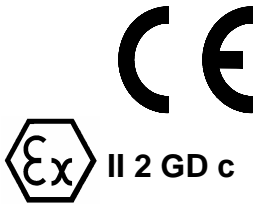
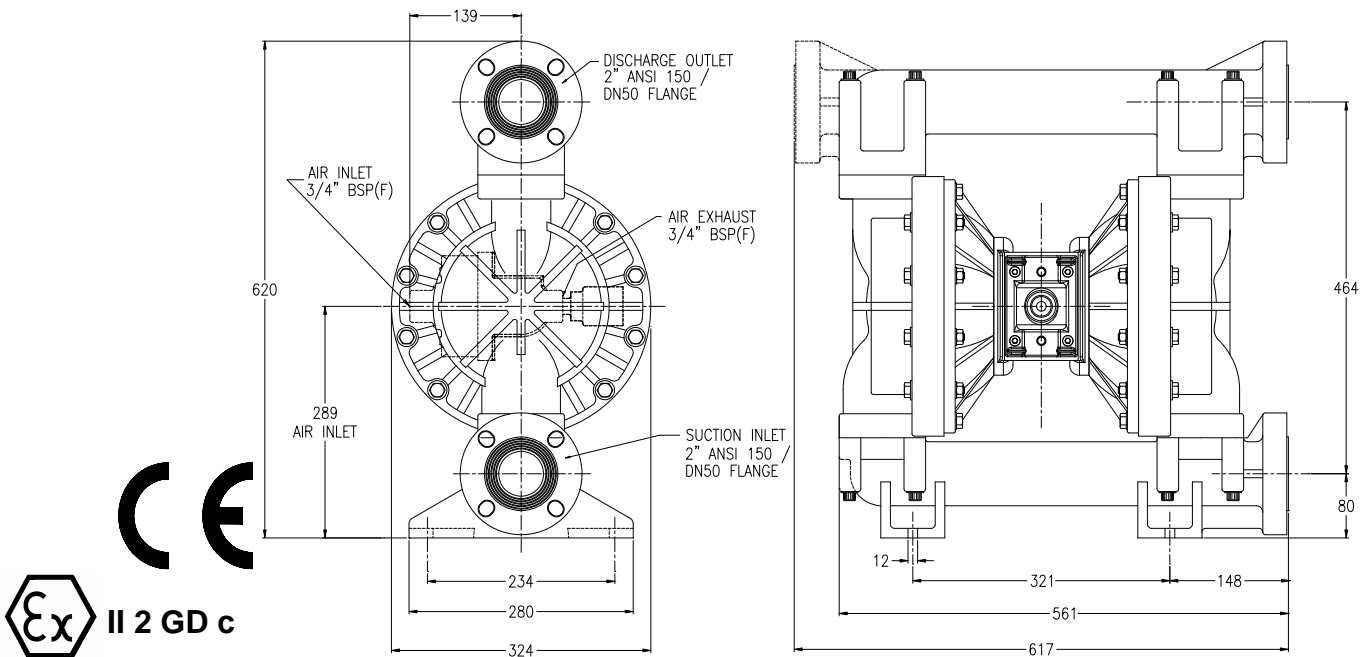

General Assembly :- B50 Moulded Pump, All dimensions +/- 3mm

B50

PERFORMANCE

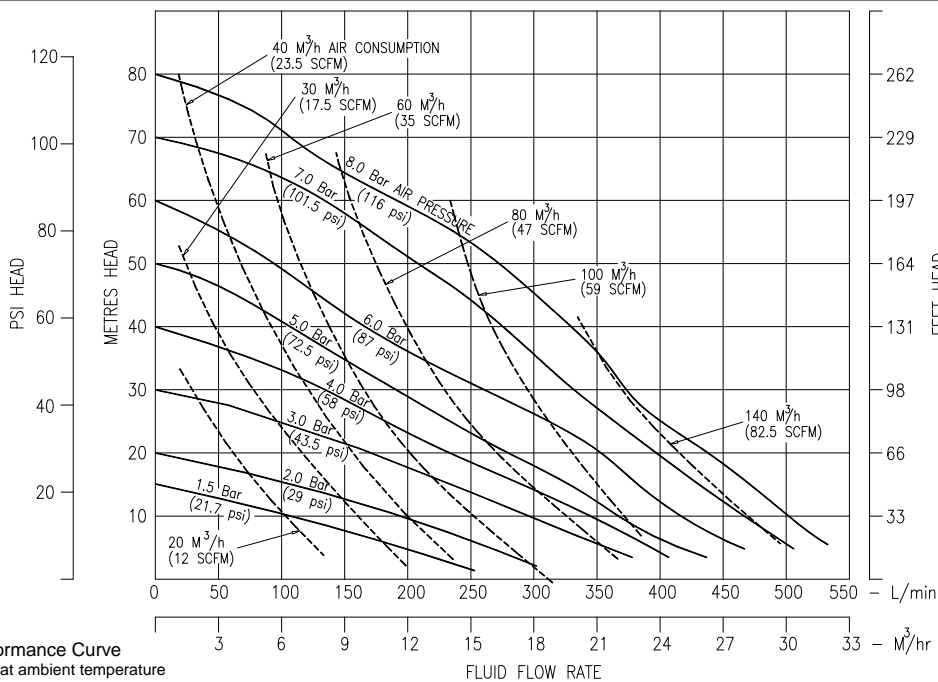

B50 Moulded Pump Performance Curve
Performance based on water at ambient temperature

FLUID CONNECTIONS 2" ANSI 150 / DN50 Compatible Flange	CAPACITY 0 - 500 Litres/Minute (0 - 110 Gallons/Minute)	MAX SOLIDS 6 MM (1/4")	MAX DISCHARGE HEAD 88 Meters (289 ft)	DISPLACEMENT/STROKE 1.9 Litres (0.42 UK Gallons)
MAX. WORKING PRESSURE 8.6 Bar (125 psi)	AIR INLET 3/4" BSP (F)	TEMPERATURE LIMITS Polypropylene :- 70°C PVDF (Kynar) :- 90°C		PUMP WEIGHTS :- PT/GT :- 38 Kg PW/GW :- 70 Kg KT :- 48 Kg KW :- 80 Kg

ⓘ Caution - Operating temperature limitations are as follows:

Operating Temperatures

Materials

Maximum Minimum Optimum

Buna-n - General purpose, oil resistant. Shows good solvent, oil, water and hydraulic fluid resistance. Should not be used with highly polar solvents like acetone and MEK, ozone, chlorinated hydrocarbons and nitro hydrocarbons.	176°F 80°C	-18°F -28°C	50° to 140°F 10° to 60°C
EPDM - Shows very good water and chemical resistance. Has poor resistance to oils and solvents, but is fair on ketones and alcohols.	212°F 100°C	-11°F -24°C	50° to 212°F 10° to 100°C
Neoprene - All purpose. Resistant to vegetable oil. Generally not affected by moderate chemicals, fats greases and many oils and solvents. Generally attacked by strong oxidising acids, ketones, esters, nitro hydro carbons and chlorinated aromatic hydrocarbons.	212°F 100°C	-4°F -20°C	50° to 130°F 10° to 54°C
Santoprene® - Injection moulded thermoplastic elastomer with no fabric layer. Long mechanical flex life. Excellent abrasion resistance.	212°F 100°C	-10°F -23°C	50° to 212°F 10° to 100°C
PTFE - Chemically inert, virtually impervious. Very few chemicals are known to react chemically with PTFE : molten alkali metals, turbulent liquid or gaseous fluorine and a few fluoro-chemicals such as chlorine trifluoride or oxygen difluoride which readily liberate free fluorine at elevated temperatures.	356°F 180°C	32°F 0°C	50° to 212°F 10° to 100°C
Viton® - Shows good resistance to a wide range of oils and solvents : especially all aliphatic, aromatic and halogenated hydrocarbons, acids, animal and vegetable oils. Hot water or aqueous solutions(over 70°F) will attack Viton®.	356°F 180°C	0°F -18°C	75° to 212°F 24° to 100°C
Polypropylene - High strength, light weight, corrosion resistant polyolefin which easily withstands most chemicals, with no known solvent at room temperature.	158°F 70°C	-40°F -40°C	50° to 140°F 10° to 60°C

TYPICAL CODE = B50. 02 P T. B B. T T P - T

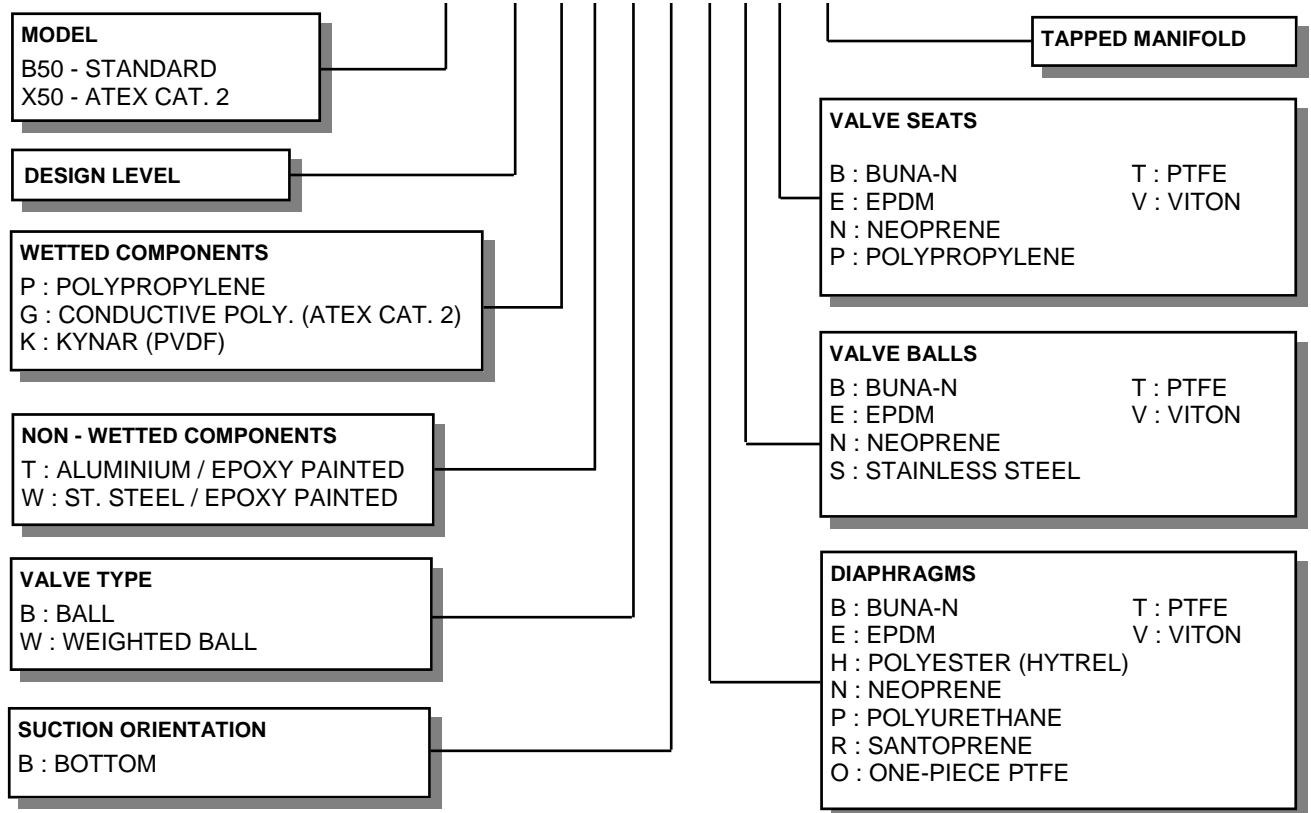

IMPORTANT

This pump should be used in accordance with the requirements of the Health and Safety at Work Act 1974. All business conducted subject to Blagdon Pump. Terms and Conditions of Sale, available on request.



LAMBERT ROAD, ARMSTRONG, WASHINGTON,
TYNE & WEAR NE37 1QP ENGLAND.
TEL. : 0044 (0) 191 4177475
FAX. : 0044 (0) 191 4175435
Web Site : www.blagdonpump.com
E-Mail : sales@blagdonpump.com